CY-PM StageMax14

1400W LED BSWF Profile

User Manual



Please read the instructions carefully before use

Orders to record

1. Precautions and installation	1
1.1 Statement	1
1.2 Maintenance	1
1.3 Product Precautions	1
1.4 Product Introduction	1
1.5 Connecting Signal Cables	2
1.6 Installation of Lamps	2
2. Control Panel	4
2.1 Key Description	4
2.2 Main Menu	5
2.2.1 DMX Settings	5
2.2.2 Switching between Medium and En	5
2.2.3 Lamp Information	6
2.2.4 Lighting setup	7
2.2.5 Running Mode	8
2.2.6 Factory Settings	9
3. Channel function	10
3.1 Table of channels	10
4. Common faults	13

1. Precautions for Installation Precautions for installation

1.1 The statement

Thank you for choosing our products! This product at the factory, the performance is intact, the package is complete. For your safe and effective use of this product, please read this manual carefully and completely before you use this product. This instruction manual contains important information for installation and use. Please install and operate according to the instructions. Meanwhile, please keep this instruction manual properly for use at any time. Our company does not assume any responsibility for the damage of lamps or other performance due to the failure of individuals to follow the instructions during installation, use or maintenance.

This manual is subject to technical change without prior notice.

1.2 Maintenance and maintenance

- Please disconnect the power supply before maintenance.
- The lamp should be kept dry and avoid working in wet environment.
- Intermittent use will effectively extend the life of the lamp.
- For good ventilation and lighting, take care to clean the fan and fan net as well as the lens frequently.
- Do not rub the lamp shell with alcohol and other organic solvents to avoid damage.

1.3 Product Precautions

- This lamp is for professional use only.
- Before running, ensure that the power supply voltage is consistent with the required power supply voltage.
- Do not place the product in a place that is easy to loosen or vibrate.
- In the process of use, if the lamp is abnormal, it should stop using the lamp in time.
- In order to ensure the service life of the product, the product should not be placed in a damp or leaking place, and should not work in an environment where the temperature exceeds 60 degrees.
- When the bulb is used, the power supply voltage should not be more than $\pm 10\%$. If the voltage is too high, the life of the bulb will be shortened. If the voltage is too low, the light color of the bulb will be affected.
- After power failure, it takes 20 minutes for the lamp to be fully cooled before it can be powered on again.
- The rotating part of the lamp and the sticking parts must be checked regularly. If loose or shaking occurs, it should be reinforced in time to prevent accidents.
- To ensure the normal use of this product, please read the instructions carefully.

1.4 Product Introduction

- Power of light source: W;
- Voltage: AC 200V~240V/50~60Hz;
- Color disk: Each color disk consists of color plates + white light;
- Pattern plate: pattern effects;

- 540° translation, 270° tilt.
- Overheating protection;
- Control mode: DMX512/ master-slave/automatic;
- IP20 protection level

1.5 Signal wire connection

Lamps feature standard DMX input and output 3-core or 5-core XLR sockets. Please use DMX 512 shielded twisted-pair signal cable; The signal line is generally connected at a distance of 150 meters, and the DMX512 signal amplifier must be added when the long-distance signal is transmitted.

Connect a shielded twisted-pair signal line from the DMX outlet of the controller to the DMX input of the first device, and from the DMX input of the first device to the DMX input of the second device, and so on, until all lights are connected. Then install a terminal plug on the last connecting 3-core jack of the light fixture output in each row. (Weld a 4/1 W, 120Ω resistance between pins 2 and 3 of the 3-core pin cannon plug).

Important: Wires should not touch each other or the metal case.

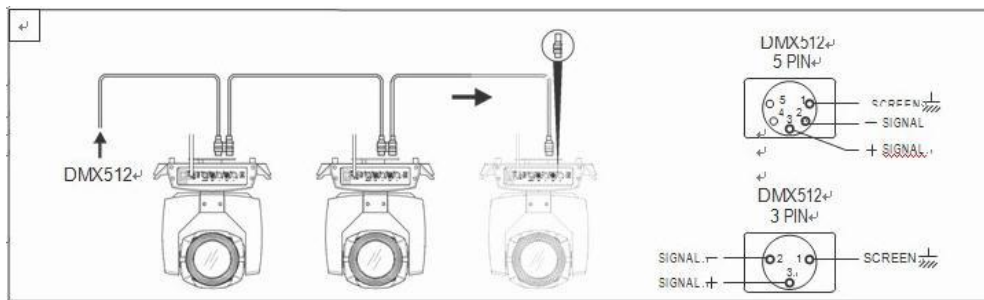

Figure 1 Schematic diagram of DMX signal cable connection

➤ Calculation method of initial address code of lamps:

The initial address code of the current lamp is equal to (the initial address code of the previous lamp)+(the number of channels of the lamp)

1: The starting address code of the first lamp is A001.

2: The basic channel number of the controller should be greater than or equal to the total number of channels used by the lamp.

3: Note: when using any controller, each lamp should have its own initial address code, if the first lamp's initial address code is set A001, the lamp channel number is 16CH; Then the initial address code of the second lamp is set to A017; The starting address code of the third lamp is set to A033; And so on. (This setting mode also needs to be determined according to different console)

1.6 Installation of lamps

Lamps can be placed horizontally, slanted or hung upside down. Pay attention to the installation method when hanging it slanting or upside down.

As shown in Figure 2, before positioning the lamp, the stability of the installation site should

be ensured. During the reverse hanging installation, the lamp must not fall down on the support frame, and the safety rope should be used to pass through the support frame and the lamp handle for auxiliary hanging to ensure safety. Prevent lamps from falling and sliding.

When the lamp is installed and adjusted, pedestrians are not allowed to pass under it. Periodically check whether the safety rope is worn and whether the hook screw is loose.

Our company does not assume any responsibility for all the consequences caused by the fall of the lamp due to the unstable installation of the hanging.

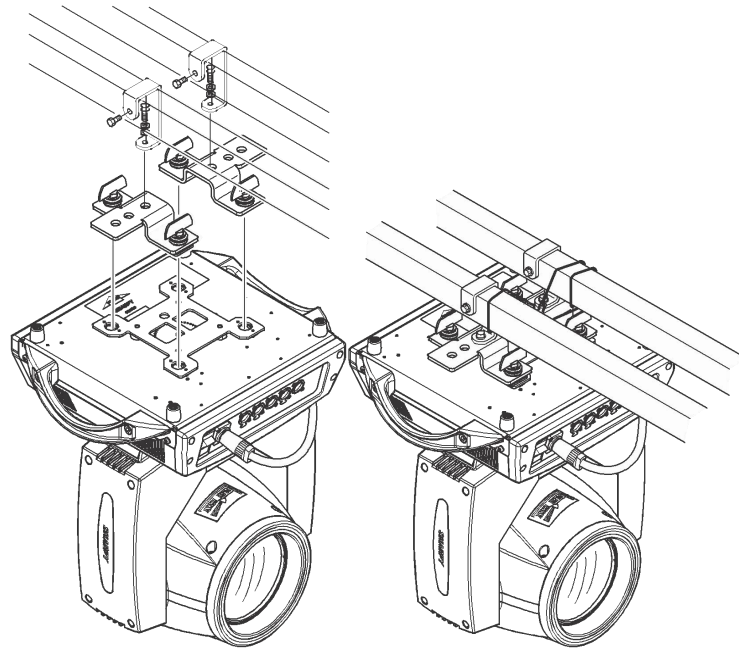

Figure 2. Schematic diagram of hanging lamps upside down

2. Control panel

2.1 Key Description

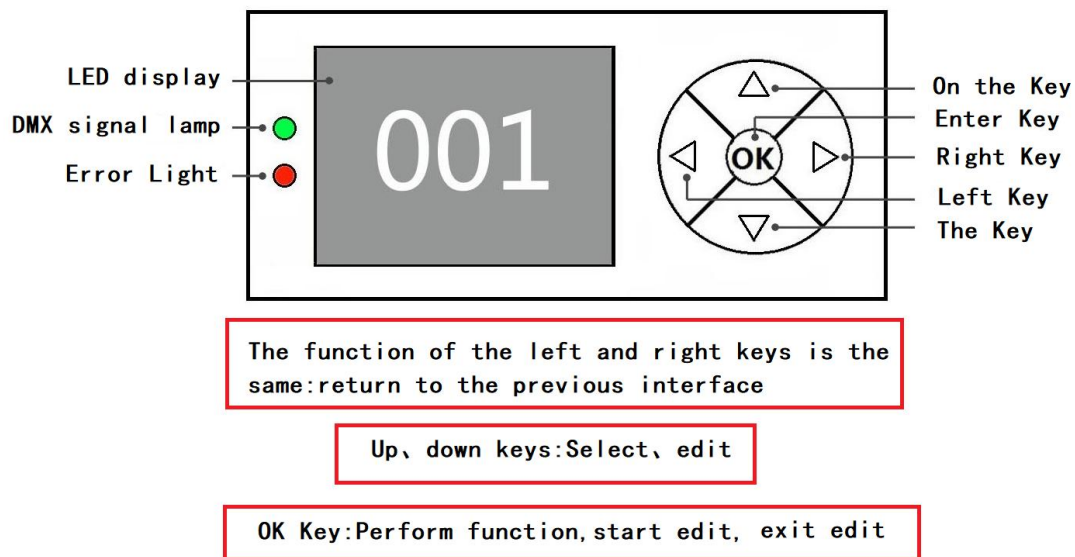

Figure 3. Description of panel keys

The following takes "Modify DMX address code" as an example to describe the use of keys:

1. If the current home screen is not displayed, press the Left key (one or more times) to return to the home screen
2. On the home screen, press the Up or Down key to select the Settings button
3. Press the OK key to enter the Settings screen
4. In the "Settings" interface, press the "Up" key or "Down" key to select "DMX Address"
5. Press "OK" to enter the editing state
6. Press the "Up" key or "Down" key to modify the DMX address code
7. Press the "OK" key to exit the editing state
8. Press the right button on the main interface to enter the calibration menu.

2.2 Menu Description

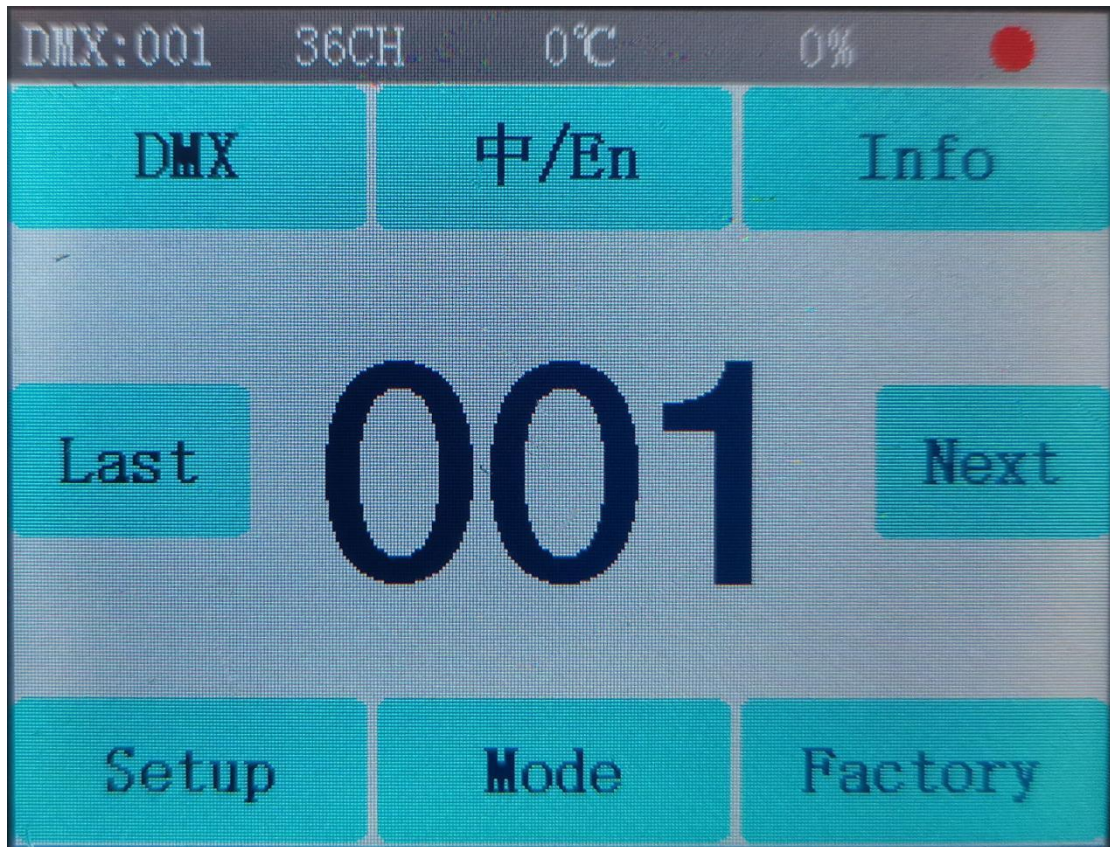

Figure 4 Main menu diagram

2.2.1 DMX Settings

Key description: Press up or down to +1 or -1 mode; Press one or the next, quickly adjust the address code mode; Press the Confirm key to return
Manual instruction: Enter the hundreds place, then the tens place, and then the last place. (For example, if you enter 286, click 2, then 8, and finally 6)

2.2.2 Medium /En

English and Chinese interface switch;

2.2.3 System Information

options	instructions	
System	DIS	Display board software version

version	MT	Motor board software version
Temperature information		Display bead temperature
Fan Information	Fan speed	Displays fan speed information
System time	Total bright bubble	Cumulative brightening time (accurate to minutes)
	This brightening bubble	The brightening time (accurate to minute)
	Total service time	Cumulative usage time (accurate to minutes)
	Time of use	Usage time since this startup (accurate to minutes)
	Date of manufacture	
	Permission Duration	9999 indicates no encryption and can be used for a long time. Other values represent the remaining use time, encrypted;
Sensor monitoring	X Hall	0 when magnetic is detected, 1 otherwise
	Y Hall	0 when magnetic is detected, 1 otherwise
	Color plate hall	0 when magnetic is detected, 1 otherwise
	CMY Hall	0 when magnetic is detected, 1 otherwise
	CTO Hall	0 when magnetic is detected, 1 otherwise
	Fixed pattern pan	0 when magnetic is detected, 1 otherwise
	Glass pattern hall	0 when magnetic is detected, 1 otherwise
	Glass pattern rotation Hall	0 when magnetic is detected, 1 otherwise
	Focus hall	0 when magnetic is detected, 1 otherwise
	Enlarge Hall	0 when magnetic is detected, 1 otherwise
	Prism 1 rotary hall	0 when magnetic is detected, 1 otherwise
	X Code disk status	Two digits, each corresponding to a photoelectric switch in the code disc
	Y Code disk status	Two digits, each corresponding to a photoelectric switch in the code disc
	X-axis encoding disk step value	The number of steps should increase when walking in the forward direction and decrease when walking in the opposite direction. Every time you go to the same point, the value is normal
	Y-axis encoding disk step value	The number of steps should increase when walking in the forward direction and decrease when walking in the opposite direction. Every time you go to the same point, the value is normal

System error		If the red ERR indicator lights up, it indicates that the lamp is running incorrectly. You can enter the sub-interface to check the details. After viewing, you can press the "Clear" key to clear the error record
DMX channel value monitoring		The sub-screen displays the channel value in numerical and percentage terms for viewing

Common Error Messages	instructions	
Failed to connect the MT board. Procedure	The motor board is not responding. The serial communication line connecting the display board and the motor board is faulty, or the motor board is faulty.	
X-axis reset failed	X-axis photoelectric switch, or X-axis motor or motor board has a problem	
Y-axis reset failed	Y-axis photoelectric switch, or Y-axis motor or motor board is faulty	
X axis Hall error	There is a problem with X shaft Hall or motor board	
Y-axis Hall error	Y-shaft Hall, or motor board problem	
Description Failed to reset the color disk	Color plate hall, or color plate motor has a problem	
Description The pattern disk failed to reset	Pattern plate hall, or pattern plate motor problem	
Failed to reset the focus	The focusing hall, or the focusing motor has a problem	

2.2.4 Lighting setup

options	instructions	
DMX channel	36CH	36 channel mode
language	Chinese	Set the interface to Chinese
	English	Set the interface to English
Screen flip	guan	Front face display

	open	The screen is displayed in reverse
Automatic screen flip	guan	Disable the automatic flip function
	open	Gravity sensing automatically reverses
Dimming curve	Square	index
	linear	A straight line
	SCurve	sine
	InSquare	logarithmic
RDM Function	guan	The RDM function is enabled
	open	Disable the RDM function
DMX signal	keep	Continue running in the original state
	reset	The motor turns back and stops running
Screen saver	guan	Turn off the screensaver
	open	Open the screensaver
Light tracing mode	guan	Shut down
	Mode 1	XY has no power in light pursuit mode
	Mode 2	Very low intensity in XY mode
X reversal	guan	The default
	open	The starting point and the ending point are switched
Reversal of Y	guan	The default
	open	The starting point and the ending point are switched
XY exchange	guan	The default
	open	Exchange XY axis channel (including fine tuning)
XY encoder	open	Use an encoder (optocoupler) to determine the out-of-step and automatically correct the position
	guan	No encoder (optocoupler) is used to correct the position
Restore Default Settings		After you press the OK key, the confirmation dialog box is displayed. Press the OK key again to restore the default Settings

2.2.5 Running Mode

Self walking mode	DMX	Slave state: Receives DMX signals from the console or host
	Since the go	Host state: Self-drive and send DMX signal to slave
	Voice control	
	Scenario 1, 2, 3	Turn on scene self - walk
	Program 1, 2, 3	Call console programming program to walk
Scenario Running	all	All open scenarios run sequentially
	From 1 to 5	Call a scene run individually
Scene Setting	Scene channel Saving	Edit number Press the "Confirm" button to save (display: saving)
	Multi-step scenario group	1, 2, 3; There are three groups

	Scene step selection	Under the current group, switch to the number of steps you want to edit
	Scene time (s)	1-100.Total time for each step to run
	Scene delay (%)	0-100;Gradient percentage, 0 is direct jump;
	Scenario Running	Open, running mode all can be called;Closing can only be invoked separately
	1 to 36 Channel values	
Console programming	Program 1, 2, 3	Switch the program position to record, press the "Confirm" button to enter the programming record interface, need to connect to the console
	Time (S)	Set the running time for each step
	They count	Current step of program
	Clearing Data	Clear all data of the current program
Console programming >> Programming interface		Adjust the number of steps up and down, connect the console to save;

Manual control (Click the operation mode menu on the main interface, select the item manual control, and press "Confirm" to enter manual control)

This interface is used to control the current lamp and automatically enter the host state (no DMX signal is received, in self-walking mode is the host, and sends DMX signal to the bus to the slave machine).

The manual menu displays 36 channels according to the standard 36 channels set in the Settings menu.

options	instructions	
1CH. X	0 ~ 255	Press the "OK" key to enter the editing state.Select the hundreds digit and press the Up and Down keys to change the channel value.Press OK again to select the tens edit.Press "OK" again to select the ones bit edit.Press again to exit the editing state
...	0 ~ 255	
35CH. Aperture	0 ~ 255	
36CH. Reset		Press the "OK" button and see the confirmation dialog box. Press the "OK" button again to enter the reset interface and reset all the motors

Reset ALL		Press the "OK" button and see the confirmation dialog box. Press the "OK" button again to enter the reset interface and reset all the motors
XY reset		Press the "OK" button to see the confirmation dialog box. Press the "OK" button again to enter the reset interface and reset XY
MT reset		Press the "OK" button and see the confirmation dialog box. Press the "OK" button again to enter

		the reset interface and reset the small motor
--	--	---

2.2.6 Factory Settings

options	instructions	
Calibration of motor	The X axis	After entering the sub-interface, you can adjust the reset position of X axis, Y axis and other motors to make up for the error in hardware installation. The adjustment range is -128 to +127, and +0 indicates no adjustment.
	Y	
	Disk of color	
	Fixed pattern plate	
	Glass pattern plate	
	Glass pattern rotation	
	Effect plate zero point	
	Stroke of effect plate	
	Apparent zero point	
	Apparent indicative stroke	
	Color temperature	
	cyan	
	magenta	
	yellow	
	focusing	
	amplification	
	Prism 1 zero point	
	Prism 1 stroke	
	Prism 2 zero point	
	Prism 2 stroke	
	Prism 1 rotation	
	Prism 2 rotation	
	Zero point of atomization	
	Stroke of atomization	
	Cutting rotary plate	
	The aperture	
	Cut 1	
Cut 2		

	Cut 3	
	Cut 4	
	Cut 5	
	Cut 6	
	Cut 7	
	Cut 8	
XY speed adjustment	X axis velocity	000-255, speed slow to fast adjustment
	Y axis velocity	
Regulation of fan	Regulation of fan	Only do temporary adjustment, power does not save
	Fan speed	

3. Function of channel

3.1 Table of channels

Channel mode					
Channel 36		Channel 42		Channel 60	
1	X	1	X	1	X
2	X_Fine	2	X_Fine	2	X_Fine
3	Y	3	Y	3	Y
4	Y_Fine	4	Y_Fine	4	Y_Fine
5	XY_Speed	5	XY_Speed	5	XY_Speed
6	Shutter	6	Shutter	6	Shutter
7	Dimmer	7	Dimmer	7	Dimmer
8	C	8	Dimming_Fine	8	Dimming_Fine
9	M	9	Zoom	9	Zoom
10	Y	10	Zoom_Fine	10	Zoom_Fine
11	CT0	11	Focus	11	Focus
12	Color	12	Focus_Fine	12	Focus_Fine
13	Slice_of_value	13	Auto_Focus	13	Auto_Focus
14	Gobo	14	Auto_Focus_Fine	14	Auto_Focus_Fine
15	Gobo2	15	Color	15	Color
16	Gobo2_Rotation	16	Slice of value	16	Color_Fine
17	Gobo3	17	C	17	Slice_of_value
18	Gobo3_Rotation	18	M	18	Slice_of_value_Fine
19	Focus	19	Y	19	C
20	Focus_Fine	20	CT0	20	C_Fine

21	Zoom	21	Gobo	21	M
22	Prism1+Prism2	22	Gobo2	22	M_Fine
23	Prism1_Rotation	23	Gobo2_Rotation	23	Y
24	Prism2_Rotation	24	Gobo2_Rotation_Fine	24	Y_Fine
25	Frost	25	Gobo3	25	CT0
26	Section 1	26	Gobo3_Rotation	26	CT0_Fine
27	Section 2	27	Aperture	27	Gobo
28	Section 3	28	Prism1	28	Gobo2
29	Section 4	29	Prism1_Rotation	29	Gobo2_Rotation
30	Section 5	30	Prism2	30	Gobo2_Rotation_Fine
31	Section 6	31	Prism2_Rotation	31	Gobo3
32	Section 7	32	Frost	32	Gobo3_Rotation
33	Section 8	33	Section 1	33	Aperture
34	Cutting disc	34	Section 2	34	Aperture_Fine
35	Aperture	35	Section 3	35	Prism1
36	Function	36	Section 4	36	Prism1_Rotation_Fine
		37	Section 5	37	Prism1_Rotation_Fine
		38	Section 6	38	Prism2
		39	Section 7	39	Prism2_Rotation
		40	Section 8	40	Prism2_Rotation_Fine
		41	Cutting disc	41	Frost
		42	Function	42	Section 1
				43	Section 1 Fine tuning
				44	Section 2
				45	Section 2 Fine
				46	Section 3
				47	Section 3 Fine
				48	Section 4
				49	Section 4 Fine
				50	Section 5

				51	Section 5 Fine
				52	Section 6
				53	Section 6 Fine
				54	Section 7
				55	Section 7 Fine
				56	Section 8
				57	Section 8 Fine
				58	Cutting disc
				59	Cutting disc Fine
				60	function

Channel parameter values (full version) :

Channel 1-36	Name	Numerical	Describe
CH1	X	0-255.	0-540 degrees
CH2	X_fine	0-255.	0-2 degrees
CH3	Y	0-255.	0-270 degrees
CH4	Y_Fine	0-255.	0-1 degrees
CH5	XY_Speed	0-255.	From fast to slow
CH6	Shutter	0-3	GuanGuang
		4-127.	From slow to fast normal stroboscopic
		128-191.	Bisect stroboscopic from slow to fast
		192-251.	From slow to fast random stroboscopic
		252-255.	medallion
CH7	Dimmer	0-255.	0-100% dimming
CH8	C	0-255.	
CH9	M	0-255.	
CH10	Y	0-255.	
CH11	CTO	0-255.	
CH12	Color	0-127.	Linear color

		128-141.	Color 1
		142-150.	Color 2
		151-160.	Color 3
		161-170.	Color 4
		171-180.	Color 5
		181-190.	Color 6
		191	Color 7
		192-222.	From fast to slow forward water
		223-224.	stop
		225-255.	From slow to fast reverse flow
CH13	Slice of value	0	There is no
		1-255.	0-100% linear insertion
CH14	Gobo	0-4	White light
		5-9	Gobo1
		10-14	Gobo2
		15-19	Gobo3
		20-24	Gobo4
		25-29	Gobo5
		30-34	Gobo6
		35-39	Gobo7
		40-44	Gobo8
		45-49	Gobo9
		50-54	Gobo10
		55-59	Gobo11
		60-69	Gobo1 Shake (From slow to fast)
		70-79	Gobo2 Shake (From slow to fast)
		80-89	Gobo3 Shake (From slow to fast)
		90-99	Gobo4 Shake (From slow to fast)
		100-109	Gobo5 Shake (From slow to fast)
		110-119	Gobo6 Shake (From slow to fast)
		120-129	Gobo7 Shake (From slow to fast)
		130-139	Gobo8 Shake (From slow to fast)
		140-149	Gobo9 Shake (From slow to fast)
		150-159	Gobo10 Shake (From slow to fast)
160-169	Gobo11 Shake (From slow to fast)		
170-212	Forward water (From slow to fast)		
213-215	Stop		
216-255	Reverse flow (From slow to fast)		
CH15	Gobo2	0-9	White light
		10-19	Gobo1
		20 - 29	Gobo2
		30-39	Gobo3
		40-49	Gobo4

		50 - 59	Gobo5
		60-69.	Gobo6
		70-79.	Gobo7
		80-89.	Gobo1 Shake(From slow to fast)
		90-99.	Gobo2 Shake(From slow to fast)
		100-109.	Gobo3 Shake(From slow to fast)
		110-119.	Gobo4 Shake(From slow to fast)
		120-129.	Gobo5 Shake(From slow to fast)
		130-139.	Gobo6 Shake(From slow to fast)
		140-149.	Gobo7 Shake(From slow to fast)
		150-190.	Forward water(Fast slow to from)
		191-192.	Stop
		193-255.	Reverse flow(From slow to fast)
CH16	Gobo2_Rotation	0-127.	Switch of angles
		128-190.	Forward water(Fast slow to from)
		191-192.	Stop
		193-255.	Reverse flow(From slow to fast)
CH17	Gobo3	0-9	Remove the
		10-255.	Linear insertion
CH18	Gobo3_Rotation	0-2	stop
		3-128.	Forward water(Fast slow to from)
		129-255.	Reverse flow(From slow to fast)
CH19	Focus	0-255.	From far to near
CH20	Focus_Fine	0-255.	
CH21	Zoom	0-255.	From small to big
CH22	Prism	0-63.	None
		64-127.	Prism 1
		128-191.	Prism 2
		192-255.	Prism 1+ Prism 2
CH23	Prism1_Rotation	0-127.	Switch of angles
		128-187.	Forward water(Fast slow to from)
		188-195.	Stop
		196-255.	Reverse flow(From slow to fast)
CH24	Prism2_Rotation	0-127.	Switch of angles
		128-187.	Forward water(Fast slow to from)
		188-195.	Stop
		196-255.	Reverse flow(From slow to fast)
CH25	Frost	0-127.	None
		128-255.	Frost Cut in
CH26	Section 1	0-255.	Linear insertion
CH27	Section 2	0-255.	Linear insertion
CH28	Section 3	0-255.	Linear insertion

CH29	Section 4	0-255.	Linear insertion
CH30	Section 5	0-255.	Linear insertion
CH31	Section 6	0-255.	Linear insertion
CH32	Section 7	0-255.	Linear insertion
CH33	Section 8	0-255.	Linear insertion
CH34	Cutting disc	0-255.	Angle of slice
CH35	Aperture	0-127. 128-255.	From big to small Function of contraction
CH36	Function	0-100.	Light tracking default (follow Settings)
		101-110.	Turn off the light chase and keep it for 5s without changing the interface Settings
		111-120.	Optical tracing mode 1: Hold for 5s without changing the interface Settings
		121-130.	Optical pursuit mode 2: Hold for 5s without changing the interface Settings
		210-215.	Reset XY for more than 6 seconds
		220-235.	More than 6 seconds reset effect motor
		240-255.	Reset all after 6 seconds

Channel 42	Channel 60	The name of the	The numerical	describe
CH1	CH1	X	0-255.	0-540 degrees
CH2	CH2	X_Fine	0-255.	0-2 degrees
CH3	CH3	Y	0-255.	0-270 degrees
CH4	CH4	Y_Fine	0-255.	0-1 degrees
CH5	CH5	XY_Speed	0-255.	From fast to slow
CH6	CH6	Shutter	0-3	GuanGuang
			4-127.	From slow to fast normal stroboscopic
			128-191.	Bisect stroboscopic from slow to fast
			192-251.	From slow to fast random stroboscopic
			252-255.	medallion
CH7	CH7	Dimmer	0-255.	0-100% dimming

CH8	CH8	Dimming _Fine	0-255.	
CH9	CH9	Zoom	0-255.	From small to big
CH10	CH10	Zoom_Fine		
CH11	CH11	Focus	0-255.	From far to near
CH12	CH12	Focus_Fine	0-255.	
CH13	CH13	Auto focus	0-63.	There is no
			64-127.	7.5 meters
			128-255.	15 meters
CH14	CH14	Auto focus fine	0-255.	
CH15	CH15	Color	0-127.	Linear color
			128-141.	Color 1
			142-150.	Color 2
			151-160.	Color 3
			161-170.	Color 4
			171-180.	Color 5
			182-190.	Color 6
			191	Color 7
			192-222.	From fast to slow forward water
			223-224.	stop
	CH16	Color_Fine		
CH16	CH17	Slice of value	0	There is no
			1-255.	0-100% linear insertion
	CH18	Slice of value Fine		
CH17	CH19	C	0-255.	
	CH20	C_Fin		
CH18	CH21	M	0-255.	
	CH22	M_Fine		
CH19	CH23	Y	0-255.	
	CH24	Y_Fine		
CH20	CH25	CTO	0-255.	
	CH26	CTO_Fine		
CH21	CH27	Gobo	0 - 4	White light
			5-9	Gobo1
			10-14	Gobo2
			15 - 19	Gobo3
			20 - 24	Gobo4
			25 - 29	Gobo5
			30-34	Gobo6
			35 - 39	Gobo7

			40- 44	Gobo8
			45-49	Gobo9
			50-54	Gobo10
			55 - 59	Gobo11
			60-69.	Gobo1 Shake (From slow to fast)
			70-79.	Gobo2 Shake (From slow to fast)
			80-89.	Gobo3 Shake (From slow to fast)
			90-99.	Gobo4 Shake (From slow to fast)
			100-109.	Gobo5 Shake (From slow to fast)
			110-119.	Gobo6 Shake (From slow to fast)
			120-129.	Gobo7 Shake (From slow to fast)
			130-139.	Gobo8 Shake (From slow to fast)
			140-149.	Gobo9 Shake (From slow to fast)
			150-159.	Gobo10 Shake (From slow to fast)
			160-169.	Gobo11 Shake (From slow to fast)
			170-212.	Forward water (From fast to slow)
			213-215.	Stop
			216-255.	Reverse flow (From slow to fast)
CH22	CH28	Gobo2	0-9	White light
			10-19	Gobo1
			20 - 29	Gobo2
			30-39	Gobo3
			40-49	Gobo4
			50 - 59	Gobo5
			60-69.	Gobo6
			70-79.	Gobo7
			80-89.	Gobo1 Shake (From slow to fast)
			90-99.	Gobo2 Shake (From slow to fast)
			100-109.	Gobo3 Shake (From slow to fast)
			110-119.	Gobo4 Shake (From slow to fast)
			120-129.	Gobo5 Shake (From slow to fast)
			130-139.	Gobo6 Shake (From slow to fast)
			140-149.	Gobo7 Shake (From slow to fast)
			150-190.	Rorward water (From fast to slow)
191-192.	Stop			
193-255.	Reverse flow (From slow to fast)			
CH23	CH29	Gobo2_ Rotation	0-127.	Switch of angles
			128-190.	Forward water (From fast to slow)
			191-192.	Stop
			193-255.	Reverse flow (From slow to fast)
CH24	CH30	Gobo2_ Rotation_ Fine		

CH25	CH31	Gobo3	0-9	Remove the
			10-255.	Linear insertion
CH26	CH32	Gobo3_ Rotation	0-2	stop
			3-128.	Forward water (From fast to slow)
			129-255.	Reverse flow (From slow to fast)
CH27	CH33	Aperture	0-127. 128-255.	From big to small Function of contraction
	CH34	Aperture_Fine		
CH28	CH35	Prism1	0-127.	Remove the prism
			128-255.	Prism 1
CH29	CH36	Prism1_ Rotation	0-127.	Switch of angles
			128-187.	From fast to slow forward water
			188-195.	stop
			196-255.	From slow to fast reverse flow
	CH37	Prism1_ Rotation_Fine		
CH30	CH38	Prism2	0-127.	Remove the prism
			128-255.	Prism 1
CH31	CH39	Prism2_ Rotation	0-127.	Switch of angles
			128-187.	Forward water (From fast to slow)
			188-195.	Stop
			196-255.	Reverse flow (From slow to fast)
	CH40	Prism 2_ Rotation_Fine		
CH32	CH41	Frost	0-127.	None
			128-255.	Frost
CH33	CH42	Section1	0-255.	Linear insertion
	CH43	Section1_Fine		
CH34	CH44	Section2	0-255.	Linear insertion
	CH45	Section2_Fine		
CH35	CH46	Section3	0-255.	Linear insertion
	CH47	Section3_Fine		
CH36	CH48	Section4	0-255.	Linear insertion
	CH49	Section4_Fine		
CH37	CH50	Section5	0-255.	Linear insertion
	CH51	Section5_F		

		ine		
CH38	CH52	Section6	0-255.	Linear insertion
	CH53	Section6_Fine		
CH39	CH54	Section7	0-255.	Linear insertion
	CH55	Section7_Fine		
CH40	CH56	Section8	0-255.	Linear insertion
	CH57	Section8_Fine		
CH41	CH58	Cutting disc	0-255.	Angle of slice
	CH59	Cutting disc_Fine		
CH42	CH60	Function	0-100.	Light tracking default (follow Settings)
			101-110.	Turn off the light chase and keep it for 5s without changing the interface Settings
			111-120.	Optical tracing mode 1: Hold for 5s without changing the interface Settings
			121-130.	Optical pursuit mode 2: Hold for 5s without changing the interface Settings
			210-215.	Reset XY for more than 6 seconds
			220-235.	More than 6 seconds reset effect motor
			240-255.	Reset all after 6 seconds

4. Common Faults

In view of some common faults, the corresponding solutions are put forward. Any problems that cannot be resolved should be dealt with by professionals. Disconnect the lamp before maintaining it.

1. Light bulb doesn't work

- Check that the voltage is installed to match the luminaire;
- Check whether the lamp power supply connection or control switch is in bad contact;
- Check for insufficient power supply;
- Check whether the DMX512 controller is sending instructions.

2. The lamp will not be controlled by the console after normal reset

- Check whether the digital starting address value and function options of the lamp are correct;
- Check whether the communication control line is connected correctly, the communication line is too long or has been interrupted;
- Check the failure of the control equipment, check the failure of the serial access signal amplifier;
- Check whether the communication line is too long or other equipment interferes with each other;
- Optimize the wiring, shorten the length of the control signal line, and separate the high-voltage and low-voltage lines;
- Add signal amplifier;
- The signal line adopts high quality shielded twisted pair wire;
- Connect the signal terminal resistor (120 ohms) at the end of the lamp.

3. Light fixture fails to start

- Check whether the power supply parameters are consistent with the lamp;
- Check the lamps in the long distance transportation process due to extrusion deformation, internal parts vibration, damp and other reasons, resulting in poor contact
Or fall off.
- Please check whether the internal wire integration plug is loose or loose.
- Check whether the electronic components of the lamp (such as electronic transformer, PCB board, motor control board, etc.) are loose, short circuit and burned out.

4. When working, the action of X or Y axis of the lamp is abnormal

- Follow the previous step to check one by one;
- Check whether the transmission belt corresponding to the X and Y axis in the lamp falls off or breaks;
- Check whether the data feedback receiver (optocoupler) corresponding to the X and Y directions in the lamp is damaged;
- Restart the machine and reset it once.